

Series 49

MINIATURE SEALED ESD RESISTANT

This switch series is rugged, panel sealed, available with round or square bezels and LED lighted or non-lighted. Bushing mount or snap-in mounting available. Series 49 switches are ideal for demanding applications in harsh environments where water, moisture or dust are problematic.



ACTUAL SIZE

APPLICATIONS

- Industrial equipment control handles
- Dog training control modules
- Outdoor controls
- Medical equipment
- Beverage dispensing

KEY FEATURES:

- Normally open or closed circuitry
- Momentary action
- LED lighted or non-lighted
- .110 Quick Connect or Solder terminals available
- Gold contacts
- ESD 15KV minimum
- Panel sealed to IP67
- Long life – up to 1 million cycles
- Threaded or snap-in mounting

ORDERING INFORMATION:

Part Number	Body Style	Button Color	LED Color	Contacts	Terminals
49-111	Round bezel	Black	—	Normally Open	Solder
49-112	Round bezel	Red	—	Normally Open	Solder
49-113	Round bezel	Green	—	Normally Open	Solder
49-114	Round bezel	White	—	Normally Open	Solder
49-115	Round bezel	Yellow	—	Normally Open	Solder
49-116	Round bezel	Blue	—	Normally Open	Solder
49-411G	Illuminated round	Black	Green	Normally Open	Solder
49-411R	Illuminated round	Black	Red	Normally Open	Solder
49-412G	Illuminated round	Red	Green	Normally Open	Solder
49-412R	Illuminated round	Red	Red	Normally Open	Solder
49-413G	Illuminated round	Green	Green	Normally Open	Solder
49-413R	Illuminated round	Green	Red	Normally Open	Solder
49-9111	Snap-in round	Black	—	Normally Open	Solder
49-9112	Snap-in round	Red	—	Normally Open	Solder
49-9113	Snap-in round	Green	—	Normally Open	Solder
49-611	Round bezel	Black	—	Normally Closed	Solder
49-612	Round bezel	Red	—	Normally Closed	Solder
49-613	Round bezel	Green	—	Normally Closed	Solder
49-131	Round bezel	Black	—	Normally Open	.110 QC
49-132	Round bezel	Red	—	Normally Open	.110 QC
49-133	Round bezel	Green	—	Normally Open	.110 QC

STANDARDS / AGENCY / RATINGS:



49-11X & 49-61X SERIES

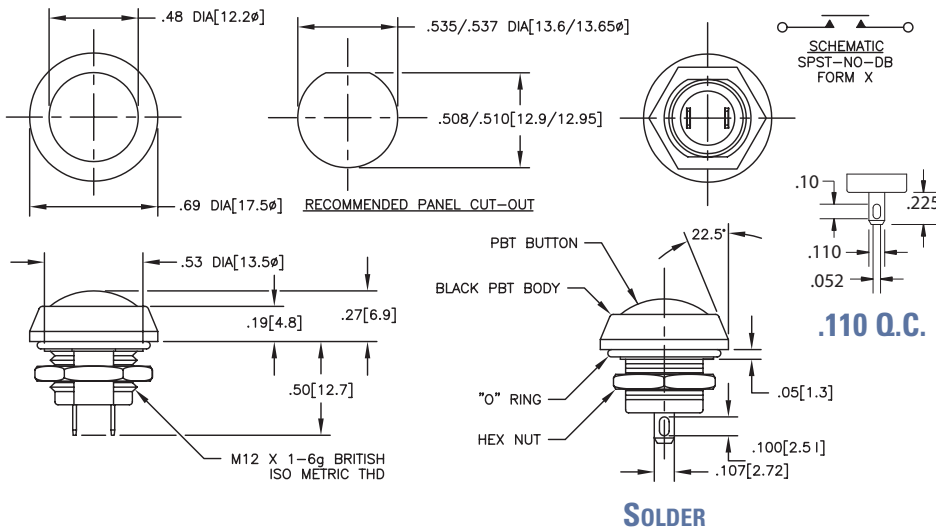

49-41X SERIES

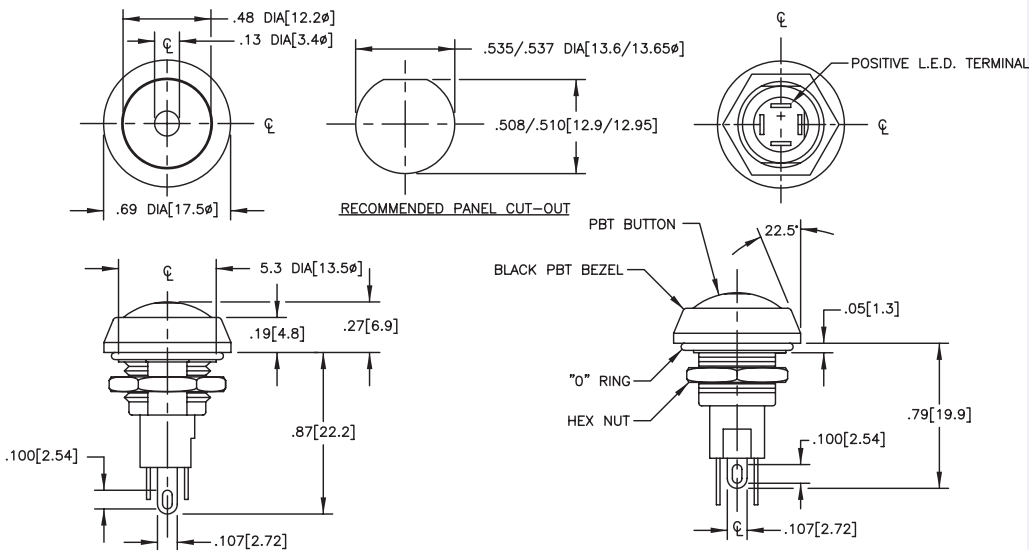

49-91X SERIES

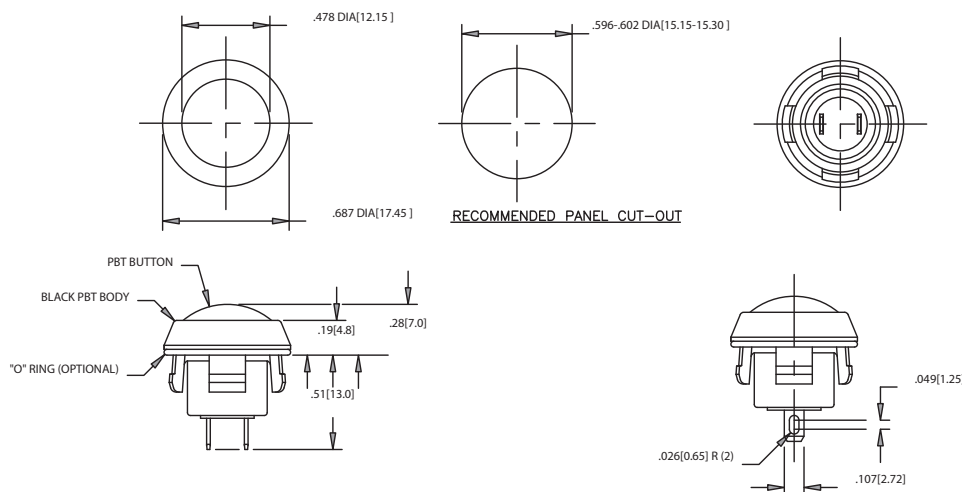

MECHANICAL / ELECTRICAL CHARACTERISTICS:

Circuit:
SPST-NO-DB or SPST-NC-DB

Travel (nominal):
0.09 inches / 2.3 mm

Life (nominal):
1,000,000 cycles (mechanical)
500,000 cycles (electrical)

Operating temperature:
-20°C to +85°C
(-4°F to +185°F)

Operating force (nominal):
3N / 306 grams

Contact bounce (nominal):
1 millisecond

LED:
T-1

Dielectric strength:
1,000 VAC

Insulation resistance:
1 GΩ

Contact resistance:
50 mΩ max (initial)

Switching power (max):
16 VA AC

Mounting Torque (max):
15 inch pounds

Electrical Ratings:

Circuitry	Current	Voltage
SPST-DB-NO	400 mA	32 VAC Res
SPST-DB-NC	100 mA	50 VDC Res
	125 mA	125 VAC Res