

Series 76-59

EXTRA TOUGH VANDAL RESISTANT SEALED PUSHBUTTON SWITCH

The Series 76-59 is an extra tough, stainless steel sealed pushbutton. It is made to withstand rough use and the concave stainless button makes it ADA compatible. The switch is momentary action and the button is available in a stainless or red powder coated button.



ACTUAL SIZE

APPLICATIONS

- Security systems
- Kiosks
- Process control
- Public access equipment
- Gas pumps
- Outdoor machinery
- Industrial machinery

KEY FEATURES:

- Sealed to IP67
- SPST-NO-DB
- Stainless steel body and button
- .110 quick connect terminals
- Standard ITW Pancon connector available
- Extra ruggedized construction
- ADA compatible

ORDERING INFORMATION:

Part Number	Bushing	Button
76-59200	Stainless steel	Raised concave stainless steel
76-59300	Stainless steel	Raised concave brass with UV stabilized red powder coat finish

STANDARDS / AGENCY / RATINGS:



76-59200 & 76-59300

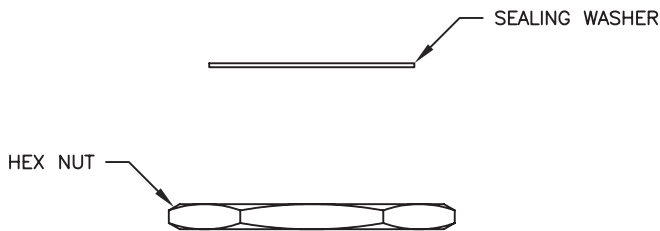
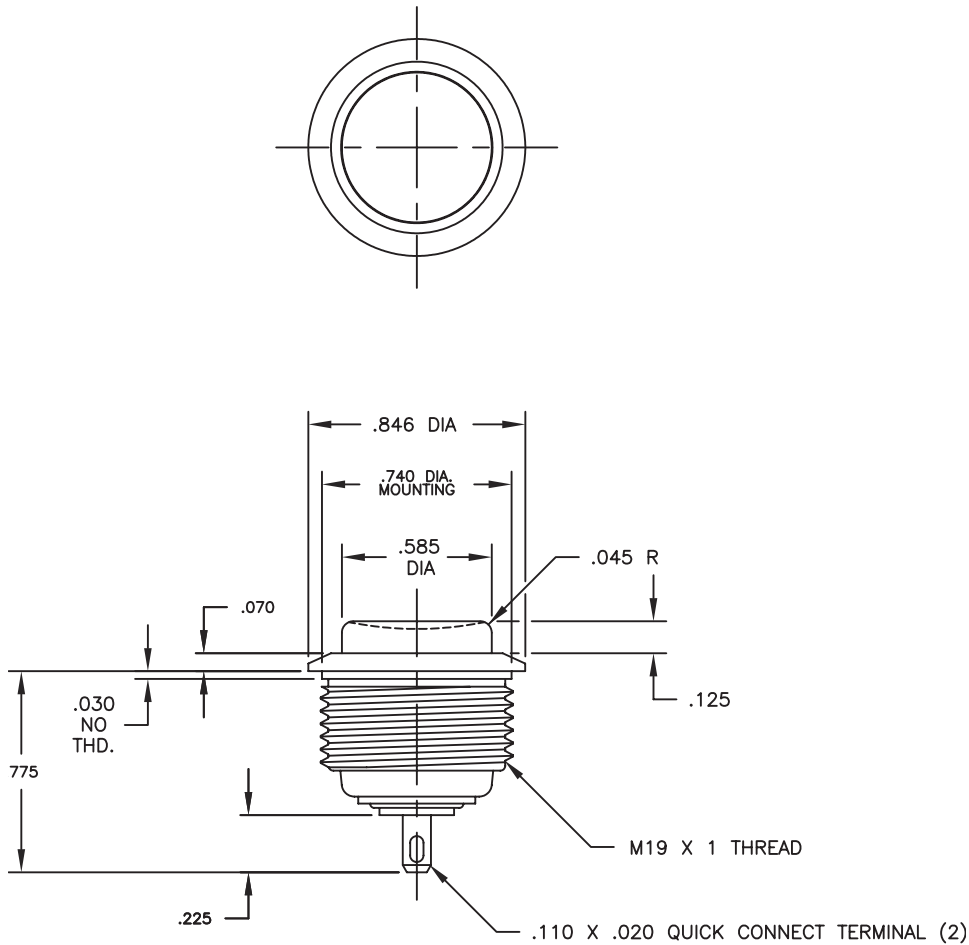

MECHANICAL / ELECTRICAL CHARACTERISTICS:

Electrical rating:

100 mA max @
50 VDC Resistive

Life (electrical):

500,000 cycles @ max load

Operating force:

3.0 N ref

Operating temperature:

-55°C to +125°C

Bushing material:

stainless steel

Button material:

stainless steel (76-59200) or
brass with UV stabilized red
powder coat finish (76-59300)

Contacts & terminals:

gold plated brass

Switch terminals mate with

ITW Pancon Connector

CSF-MH-0202

Recommended panel cutout:

0.758 inch diameter

Recommended panel

thickness:

0.06 – 0.31 inches